

FOGIA



FOGIA has been making furniture since 1981. We've grown in size, in stature and in outlook, from our beginnings as a little Swedish producer. Today, Fogia is a design brand that seeks to surprise and challenge the conventions of the industry, while honouring the aspects of design that still makes it so creatively compelling.

It's not that we don't want to fit in. We just don't seem to do things in the way they are expected to be done. With a few exceptions, Fogia's products are still made to order, by hand in our own factory in Poland. And we're happy to collaborate with designers based simply on whether it's going to be innovative and fun.

Our design partners are encouraged to take risks, to work alongside the artisans at our factory and stretch what's possible, blending traditional craft with modern production methods. And we all strive to uphold our responsibility to produce sustainably and work ethically. It's a design process that's brought about iconic products that typify Fogia's bold, yet timeless, aesthetic.

Why conform? What does that give you, our customers? We don't want to conform to a standard, we want to lift our work above those standards to give you pieces that you'll adore forever. Pieces with unmatched levels of craftsmanship and quality. Beautiful, edgy, elegant, timeless design that excites the beholder.

Don't conform, live with Fogia.



Contents

Product Index	9
Colour You Good	11
He of the Forest	19
Seating	27
Tables	79
Shelves & Storage	97
Accessories, Lighting & Rugs	109
Designers	118
Collection Overview	120
Surfaces & Stains	134
Specifications	137

Product Index

Alex High	74	Enclose	63	Persimon	114
Arch	104	Figurine Chair	68	Poppy	62
Archetto	105	Figurine Table	95	Retreat	72
Area	94	Fragment	34	Ribbon	116
Barba	46	Grande	85	Ropemaker	117
Big Sur	88	Hood	42	Sling	67
Block	40	Jord	66	Spisolini	50
Bollo	60	Kimi	110	Supersoft	43
Bond	100	Koku	80	Supersolid	82
Boss	106	Lara	90	Supper	93
Bowl	107	Luft	112	Tabula	84
Campo	76	Lyra	41	Tiki	56
Ceramics	113	Mame	61	Tondo	70
Combiplex	131	Mono	30	Upp	132
Copper	129	Morris Low	77	Utility	57
Dini	75	Myko	51	Velar	28
Embody	65	Niche	52		
Embrace	64	Pastille	92		

Colour You Good



GRAB A POSTCARD from a vendor in Stockholm and you're faced with it. Wander the streets and it seeps into your retinas. Enjoy a drink in the evening outside and it will mesmerise you. Sure, Stockholm's got its fair share of landmarks but one aspect of the city that will leave more of a mark on your psyche is how it deploys colour.

It's an amusing aspect of a capital city famed for its stylish monochrome-clad citizens, that the backdrop for their selfies are often the colourful facades of its architecture. Stockholm's vibrant, slightly dirty pastel facades are the result of traditional paints, made often from the mineral composition locked in the Swedish landscape. Some minerals were also imported from places like France and Southern Europe during the 17th and 18th century to create richer reds, pinks and oranges.



“Stockholm really is a city defined by its colour. It’s got this yellow, pinkish red and brown colour scheme. In 1699, the Swedish Governor General actually decreed that all houses be painted yellow!” explains Ida Holsner, building antiquarian at Stockholm’s Museum.

As well as being decorative, the act of painting was also a way of preserving buildings from the harsh nordic elements. And, along the way, red paint became a way for the lower classes to attempt to imitate expensive brick facades.

“Today there are a number of areas in Stockholm that are heritage sites, with our job being to preserve the facades and colours you’ll see there. While Stockholm hasn’t been decimated by war, we have had our fair share of fires and situations where landlords have altered the facades through modernisation. But there’s places like Mariaberget and Blecktornsområdet on Södermalm, Röda Bergen in Vasastan and Gamla Stan of course that are protected by regulation, and quite a few buildings are also maintained by the city,” says Holsner.



Stockholm is arguably the only city in the world that has its own colour system, NCS – Natural Color System, a colour standard based on human perception of colour and how we order it. The NCS system plays an integral part in the way city architects and planners have added colour to Stockholm over the years in a decorative and practical sense.

In Swedish society the colour of a facade is as much as an exercise in diplomacy as it is aesthetics. The unwritten rule is not to paint one’s house or building the colour you might wish, but instead to spend considerable time thinking about how it will blend in with its surroundings sympathetically. And do spare a thought for whether your neighbours will appreciate your colour sensibilities.

Visiting, say, Gamla Stan and soaking up its smudged pastel streets, cast your eyes skywards. You’ll soon see that Stockholm’s built environment also shares a relationship with the colours found in the sky. Notice the transition from skyline to atmosphere that’s natural and progressive.





On average there's no place on earth that gets more or less natural light than another. However, the viewer's position on the earth affects our perception of light and the speed of its rays as they enter the atmosphere. And in Stockholm we're treated to extended performances of sunrise and sunset, exposing us to slower transitions of the colour spectrum – especially during the summer months.

Does the constant exposure to all this colour play a part in our collections? Certainly in recent years Fogia has laid a pretty colourful foundation through its collections. And it would be hard to deny there's a tangible connection between our design and the beautiful city in which we work and thrive. As the song by legendary Swedish singer, Lasse Berghagen lays bare, Stockholm is most definitely in Fogia's heart.



He of the Forest



TODAY, the forests of Poland are deep and thick. Bleak and bitterly cold in the winters, dank and odorous in the spring. Not to mention the areas of forest filled with wild boar, wolves and huge bison. Beautiful but with a hint of the unknown – as any good forest should be.

In the Middle Ages though the forests of Central Europe were areas where few dared to venture. And the folklore connected with Polish forests and those of its neighbours are rife with chilling creatures like the water spirit Wodnik and Rusalki that haunt the lakes, rivers and swamps.





The Leshy (He of the Forest) is a mythical creature whose home is the forests of Poland. Masculine and humanlike, the Leshy can change in size and height, sometimes described as having horns and being in the company of wolves or bears.

As with many folkloric creatures of the Middle Ages, he was a tricky spirit who often lured travellers astray and abducted children. Yet, Leshy didn't always mistreat all users of the forest. And, if Leshy believed an individual or group of people was treating the forest with respect and dignity they would be left alone.

Fogia's timber is obtained from FSC-certified, sustainably managed forests in close proximity to our factory in Gdansk, to minimise associated emissions from transport and logistics. We prefer to receive whole logs, which are processed in our own saw mill and drying facility, to minimise waste. The Leshy would approve.

The importance of the forest to Poland cannot be understated. Covering almost 30% of the country's footprint, much of the forest can be found in the western and northern parts of the country but other areas like the Carpathian Mountains in the south are also covered.

During, and following the war, Poland's forests were stripped back to about 21% and lots of its rich deciduous trees were harvested and replaced by fast growing pines. Post-war Poland has since invested heavily in the preservation and reforestation to bring it back to where it is now, with projections of 33% coverage forecast for 2050.

As much as 81% of Poland's forests are state-owned, making it unique in this sense.







Seating

Velar



Sofa designed with *Andreas Engesvik*

Mono



Chair collection designed with *Note*





Fragment



Modular seating system designed with *Todd Bracher Studio*







Block



Sofa designed with *Atelier Alba*

Lyra



Chaise longue designed with *Andreas Engesvik*

Hood



Armchair designed with *TAF Studio*

Supersoft



Modular sofa system designed with *Note*



Barba



Armchair designed with *Andreas Engesvik*



Sofa designed with *Andreas Engesvik*



Spisolini



Chair designed with *Andreas Engesvik*

Myko



Chair designed with *Stefan Borselius*

Niche



Armchair designed with *TAF Studio*



Sofa designed with *TAF Studio*



Tiki



Sofa series designed with *Andreas Engesvik*

Utility



Stool designed with *Norm Architects*



Bollo



Armchair designed with *Andreas Engesvik*

Mame



Armchair designed with *Luca Nichetto*

Poppy



Pouf series designed with *Nina Jobs*

Enclose



Armchair designed with *Norm Architects*

Embrace



Armchair designed with *Norm Architects*

Embody



Footstool designed with *Norm Architects*

Jord



Modular sofa system designed with *Luca Nichetto*

Sling



Armchair and sofa designed with *Note*

Figurine



Chair designed with *Note*



Stools designed with *Note*

Tondo



Armchair designed with *Stefan Borselius*



Modular sofa system designed with *Stefan Borselius*

Retreat



Modular sofa system designed with *Monica Förster*

Alex High



Modular sofa system designed with *Koncept*

Dini



Sofa designed with *Andreas Engesvik*

Campo



Modular sofa system designed with *Stefan Borselius*

Morris Low



Modular sofa system designed with *Anika Reuterswärd*



Tables

Koku



Table series designed with *Norm Architects*

Supersolid



Object series designed with *Note*



Tabula



Table series designed with *Note*

Grande



Table series designed with *Note*



Big Sur



Sofa table and desk designed with *Simon Klenell & Kristoffer Sundin*

Lara



Table designed with *Andreas Engesvik*

Pastille



Side table designed with *TAF Studios*

Supper



Table series designed with *Andreas Engesvik*

Area



Table designed with *Note*

Figurine



Table designed with *Note*



Shelves & Storage



Bond



Modular shelving system designed with *MAIN*





Arch



Shelf designed with *Note*

Archetto



Shelf designed with *Note*

Boss



Series of cabinets designed with *Bo Westerdahl*

Bowl



Table/storage designed with *Andreas Engesvik*

Accessories, Lighting & Rugs



Kimi



Mirror designed with *Carina Seth Andersson*

Luft



Vase designed with *Luca Nichetto*

Ceramics



Pots and planters designed with *Carina Seth Andersson*

Persimon



Lighting series designed with *Note*



Ribbon

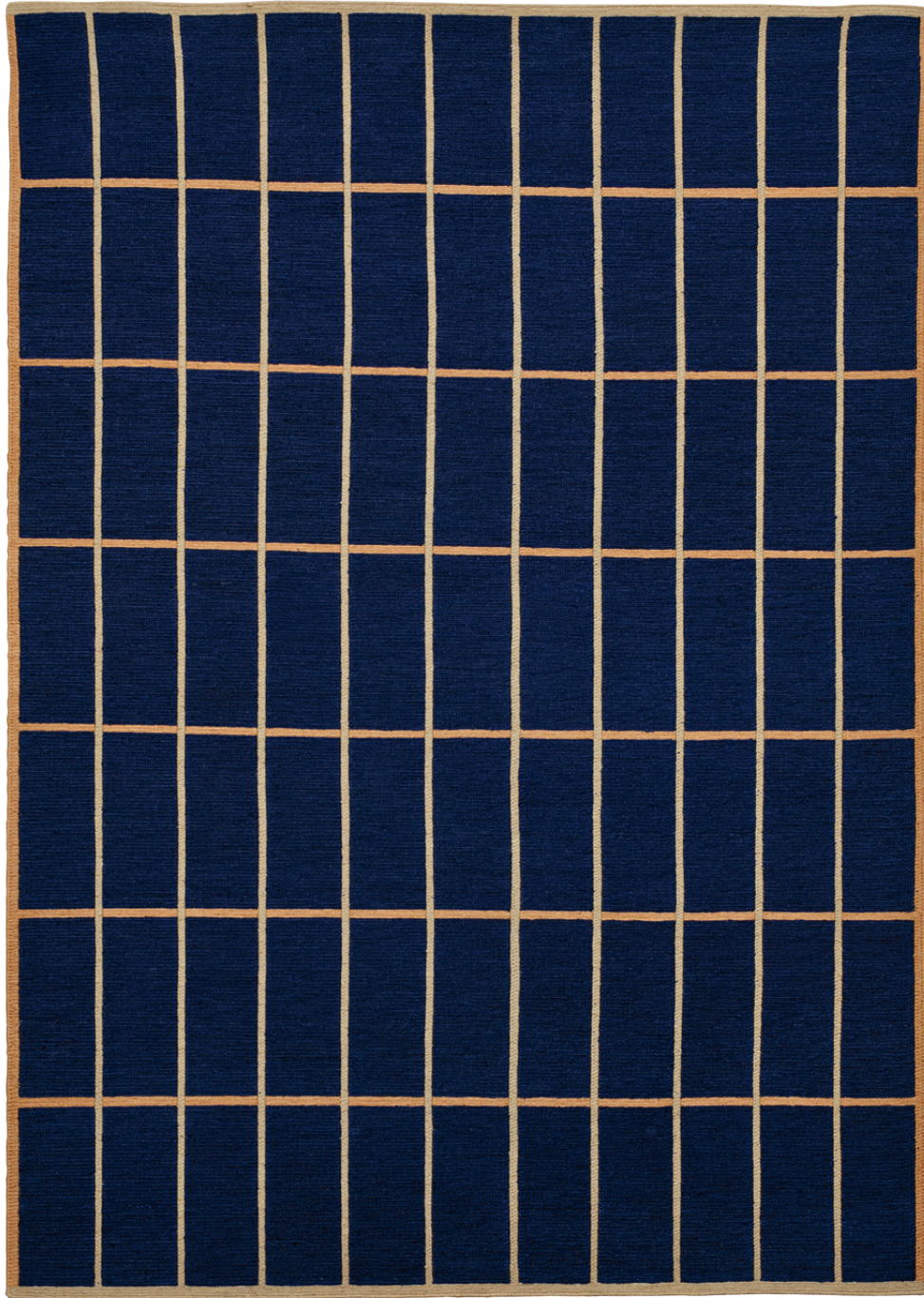

Rug designed with *Andreas Engesvik*

Ropemaker



Rug designed with *TAF Studio*

ANDREAS ENGESVIK

Norwegian designer, Andreas Engesvik is one of Fogia's most prolific collaborators. At the helm of his eponymous studio since 2010, he's the mind behind Fogia's iconic Tiki, Dini, Bollo and Barba. Influenced by the classic lines of Italian sports cars, his retro-futuristic forms have made him a legend in the Fogia universe.

ANIKA REUTERSWÄRD

Anika Reuterswärd creates work that draws from her considerable experience in the field. Seeking to create pieces that can be used by everyone and enjoyed throughout their lives, she eschews avant-garde shapes and forms. Reuterswärd has had a long-standing relationship with Fogia since our beginnings.

ATELIER ALBA

Atelier Alba is a Stockholm-based architecture and interior design practice. Its work is elegant and measured, often playing with and twisting conventional scale to create eye-catching forms.

BO WESTERDAHL

With a lengthy career spanning decades, Bo Wester Dahl emerged from design school and nestled under the wing of Carl Malmsten, his professor, to cut his teeth at Malmsten's studio. A creator whose place in Sweden's design legacy is assured.

CARINA SETH ANDERSSON

One of the doyennes of Sweden's craft industry, Carina Seth Andersson is a joy to behold in all respects. Her work is studied and purposeful, relying on her instincts and extensive crafting experience to make distinctive, timeless items.

DIIS

Founded in 2015 by graduates Susanne Roser and Martina Staub, Diis is Fogia's first collaborator from outside of the Nordics. In a design process that targets functional simplicity to create a lean aesthetic, Diis has a well developed slickness and personality in its pieces.

HÅKAN URDELL

Former development director at Fogia, Håkan Urdell was a unique designer and central character in the progression of Fogia as a brand. Under his guidance Fogia began to develop its reputation as makers of high quality soft seating.

KONCEPT

With its distinctive style of architecture, Koncept could lay claim to be the pioneers of Sweden's stripped back, exposed, industrial spaces in hotels like Story in Stockholm. If you can see raw brickwork, pipework latticing across a ceiling or rough concrete, it's probably the work of the studio.

LUCA NICETTO

With one foot in his homeland, Italy and the other firmly planted in Sweden, his adopted home, Luca Nichetto's studio has gained a solid reputation for its wide ranging reference points and precise design execution. His stance on the design industry and its responsibilities to the wider world we live in are informed, honest and unique.

MAIN

Elin Rahnberg and Martin Berling are an unlikely new force in Swedish design. Seemingly appearing out of nowhere with

a modular shelving system that has already been hailed a modern Swedish icon. With respective backgrounds in retail interiors and entrepreneurialism, via boat building, the pairing have hit upon a formula that results in unexpected design gold.

MONICA FÖRSTER

With some of Sweden's most iconic products bearing her name, Förster's work is characterised by a pure sense of form. As a designer, she brings a hunger to explore new typologies and ways of fusing industrial design methods with traditional crafting techniques.

NINA JOBS

Stockholm-based designer, Nina Jobs began her creative path as a graphic designer before transitioning to physical objects. Her work is often laced with natural references, and carry an underlying functional usability to help extend the product lifecycle beyond a single generation.

NORM ARCHITECTS

Design collective Norm Architects has been carving out a well-realised niche in Denmark and beyond since 2008. Guided by nature, harmonious balance and attention to detail, it builds on the classic principles of Scandinavian design, which makes them perfect collaborators for Fogia.

NOTE

From its disruptive entry into Sweden's design landscape in 2008, the Note collective can easily lay claim to being one of the most influential design studios in Sweden with a reach that today stretches

around the globe. The studio's work is multifaceted, intelligent and critically acclaimed. Note has been Fogia's design partner since 2013.

SIMON KLENELL & KRISTOFFER SUNDIN

Interior architect, Kristoffer Sundin and craft artist, Simon Klenell collaborated to create the Big Sur range for Fogia. Individually, the pair are well known for limited edition explorations into crafts. As creators they could be considered part of the back bone of Sweden's contemporary crafts scene from the end of 2009 onwards.

STEFAN BORSELIUS

With an abundance of natural talent and skilled in handcraft and carpentry techniques, Stefan Borselius is a pleasure to collaborate with. His design is a true balance of function and form, with an aesthetic that's forward thinking but timeless in its intent.

TAF STUDIO

Founded in 2002 by Gabriella Gustafson and Mattias Ståhlbom, TAF Studio has amassed a wide portfolio of pieces and projects; achieving considerable critical acclaim. The firm's reference points are rooted in the everyday; familiar forms with purposeful twists of function and material.

TODD BRACHER STUDIO

The acclaimed native New Yorker Todd Bracher, has earned worldwide attention for his clean, architectural and refined vernacular. His design is not only aesthetically pleasing but also consider contemporary culture and human needs, which harmonizes well with the Fogia philosophy.

Sofas



Block



Supersoft



Velar



Supersoft



Tiki 2 seater



Niche sofa



Tiki 3 seater



Fragment



Fragment



Fragment



Barba



Alex High



Alex



Morris



Morris Low



Sling



Dini



Retreat



Jord



Jord



Retreat 2.5 seater



Campo



Jord



Tondo



Tondo

Armchairs



Tondo



Lyra



Niche



Bollo

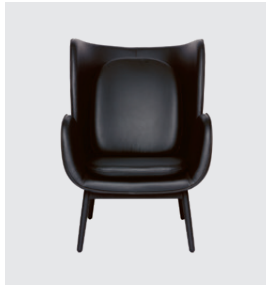

Enclose



Embrace



Barba



Alex Low



Alex High

Chairs

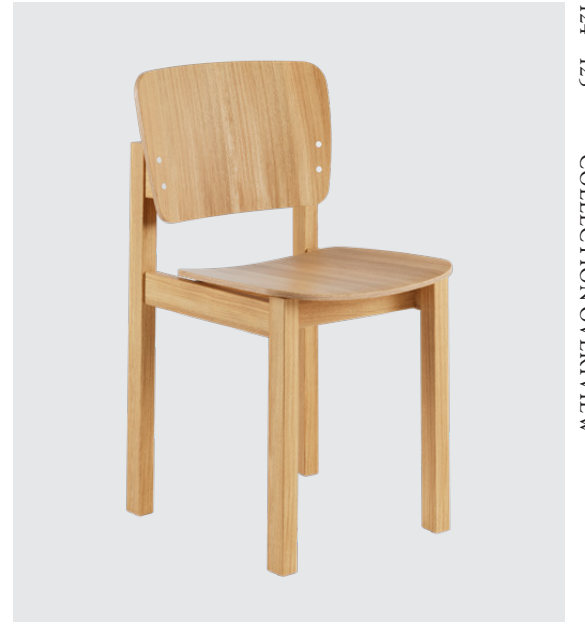

Mono



Mono



Mono



Tiki Small



Tiki Large



Mono



Mono



Mono



Hood



Mame



Tondo



Tondo



Spisolini



Myko

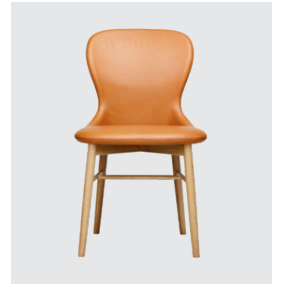

Myko



Tondo



Sling



Myko with armrests



Figurine

Stools & Poufs



Poppy Low



Poppy Small



Poppy Big



Alex



Utility Small



Utility Big



Mame



Figurine Stool



Figurine Barstool



Embody



Tiki

Tables



Koku

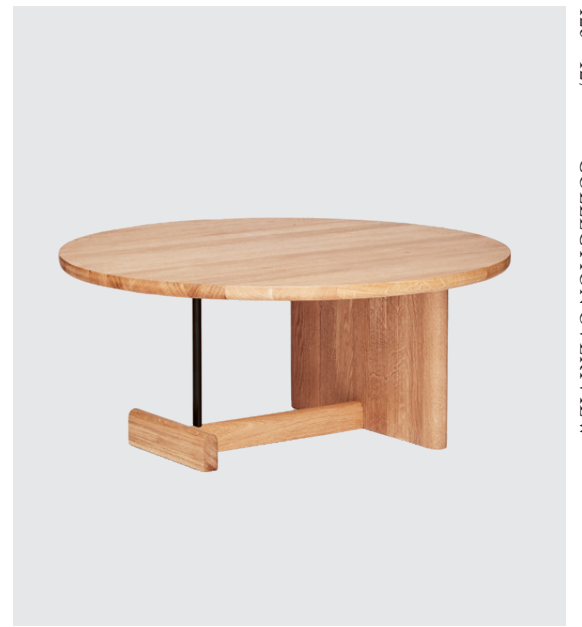

Koku



Koku



Supersolid Object 1



Supersolid Object 3



Supersolid Object 2



Supersolid Object 4



Supersolid Object 5

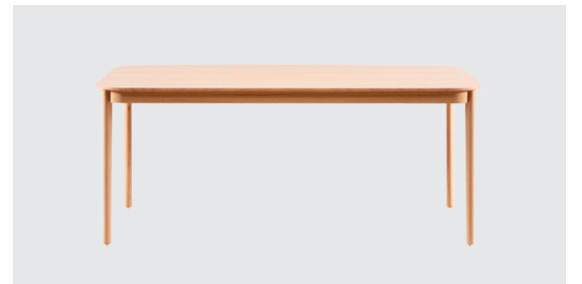

Figurine



Tabula



Pastille



Bowl



Bowl



Tabula



Supper



Supper



Grande



Nesting Table



Area



Grande



Copper



Copper



Lara



Area



Big Sur



Big Sur Desk

Shelves & Storage



Arch

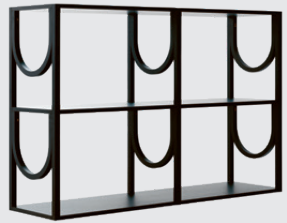

Arch



Arch



Bond W406



Bond W103



Bond W106



Bond W406D



Bond W405

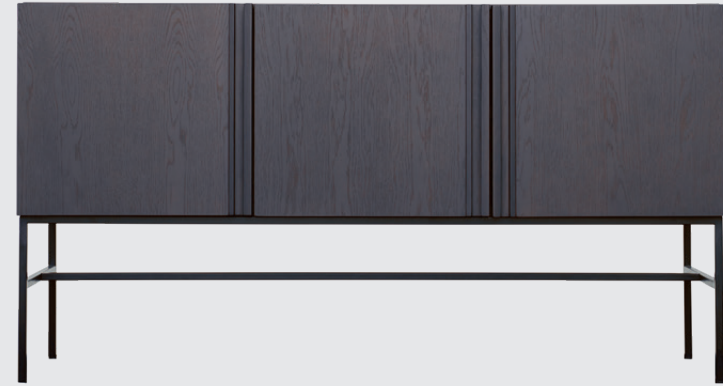

Boss



Boss



Boss

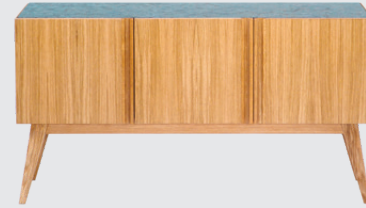

Boss



Boss



Archetto



Complex



Complex

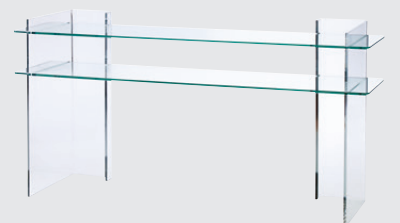

Complex

Accessories



COLLECTION OVERVIEW

Lighting



Persimon Pendant Small

Persimon Pendant Big



Kimi Small

Kimi Medium

Kimi Large



Persimon Table Big

Persimon Table Small



Persimon Cluster



Ceramics Planter



Ceramics Plate



Ceramics Pot



Luft Large

Rugs & Throws

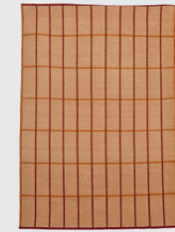

Ribbon Rust



Ribbon Beige



Ropemaker Red

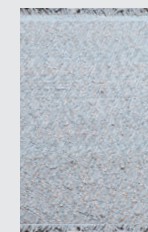

Ropemaker Blue

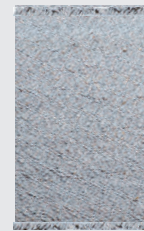

Ropemaker Stone



Ropemaker Sand

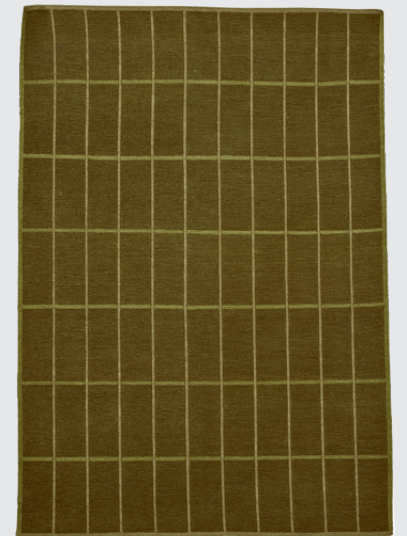

Ribbon Green



Upp Pedestal High



Upp Plate



Upp Pedestal Low



Luft Medium

Surfaces



Ash Lacquered



Beech Lacquered



Oak Lacquered

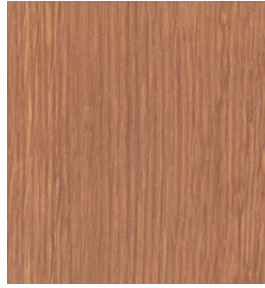

Oak Oiled



Walnut Lacquered



Walnut Oiled



Limestone



Terrazzo Botticino

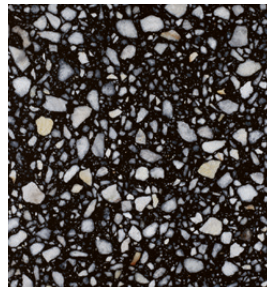

Terrazzo Daniello

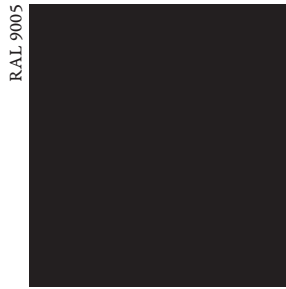

Metal Black

RAL 9005

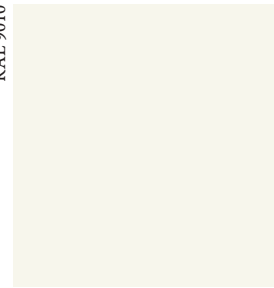

Metal White



Metal Pearl White

RAL 1013



Metal Agate Grey

RAL 7038

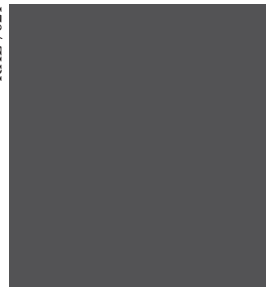

Metal Black Grey

RAL 7021

Stains

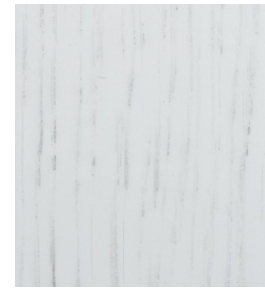

White

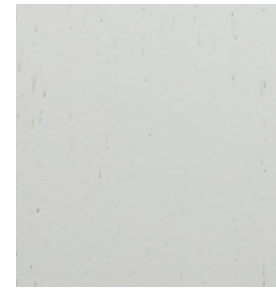

Pearl White



Grey



Red



Dark Green



Dark Blue



Black



Smoked Oak



Oak Wenge



Oak Light

Seating

Block

2 seater

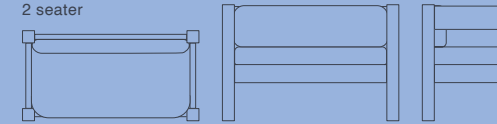

W: 116
Seat height: 52
Seat depth: 40

H: 76

D: 59

Hood

Armchair

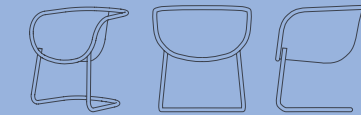

W: 68,5
Seat height: 45
Seat depth: 45

H: 73,8

D: 61,7

Lyra

Chaise longue

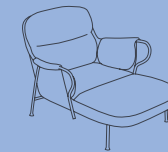

Length: 140
Width: 90
Height: 82
Seat height: 43
Seat depth: 95

Sling

Sofa

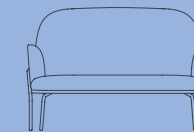

W: 125, H: 88, D: 75

Armchair

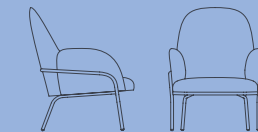

Seat height: 43
Seat depth: 49

W: 67, H: 88, D: 75

Supersoft

SECTIONS All parts can be mirrored

Corner

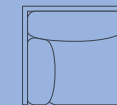

92 x 92

1 seater armrest

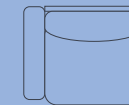

120 x 97

1,5 seater armrest

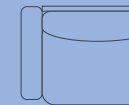

133 x 97

1 seater open-side

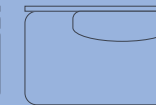

145 x 97

Height: 78
Seat height: 45

2,5 seater

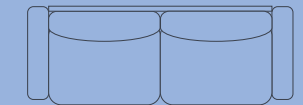

266 x 97

1 seater open-side

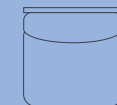

97x 97

1,5 seater open-side

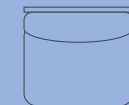

110 x 97

1,5 seater open-side

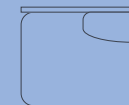

160 x 97

1,5 seater chaise longue

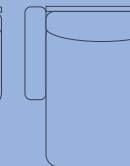

133 x 160

1 seater chaise longue

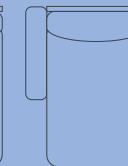

120 x 160

2 seater

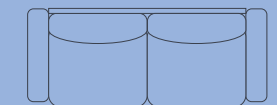

240 x 97

EXAMPLE COMBINATIONS All parts can be mirrored

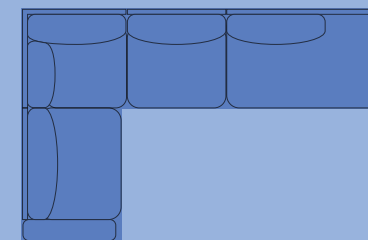

1,5 seater armrest + corner + 1 seater +
1,5 seater open-side
225 x 349

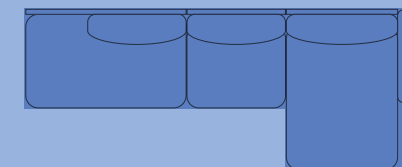

1,5 seater open-side + 1 seater + 1,5 seater
chaise longue
392 x 160

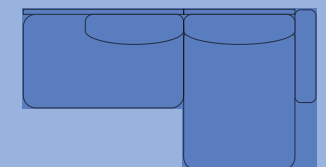

1,5 seater open-side +
1,5 seater chaise longue
295 x 160

Morris Classic / Morris Low

SECTIONS All parts can be mirrored

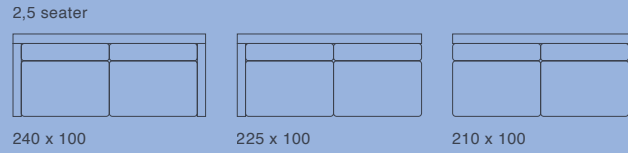
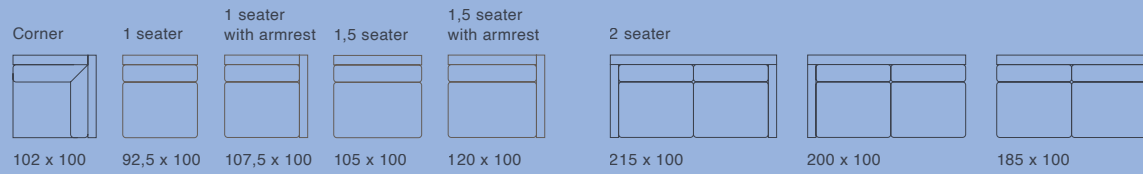

MORRIS LOW
 Total height: 74
 Seat height: 47
 Seat depth: 55

MORRIS
 Total height: 77
 Seat height: 47
 Seat depth: 55

Chaise longue



90 x 180

Morris Loveseat

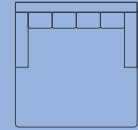

165 x 165

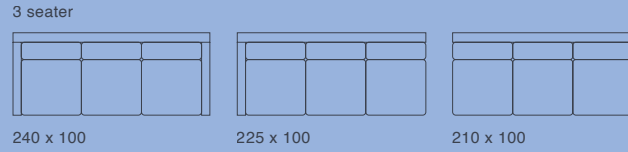

EXAMPLE COMBINATIONS All parts can be mirrored

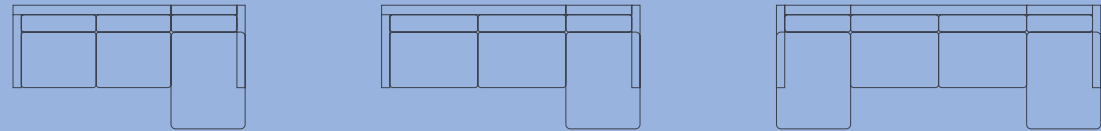

2 seater + chaise longue
290 x 180

2,5 seater + chaise longue
315 x 180

Chaise longue + 2,5 seater + chaise longue
390 x 180

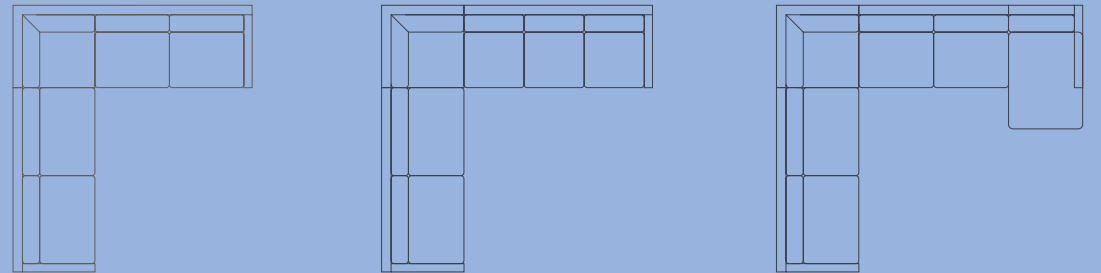

2,5 seater + corner + 2 seater
327 x 302

2,5 seater + corner + 3 seater
327 x 327

2,5 seater + corner + 2 seater + chaise longue
327 x 377

Dini

Seat depth: 58, seat height: 42

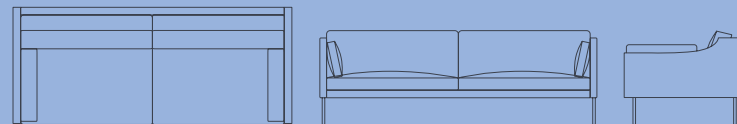

W: 220

H: 68

D: 92

Tiki

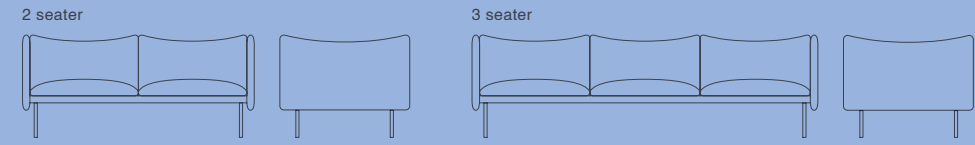

W: 162, H: 77

D: 93

W: 236, H: 77

D: 93

Arm height: 77
 Seat height: 40
 Seat depth: 58

Armchair small

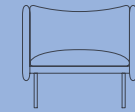

W: 70, H: 70
 Seat height: 40
 Seat depth: 46

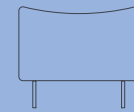

D: 75

Armchair large

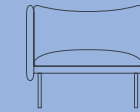

W: 86, H: 77
 Seat height: 40
 Seat depth: 58

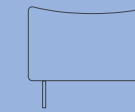

D: 93

Stool



67 x 34,5
 Seat height: 34,5

Campo

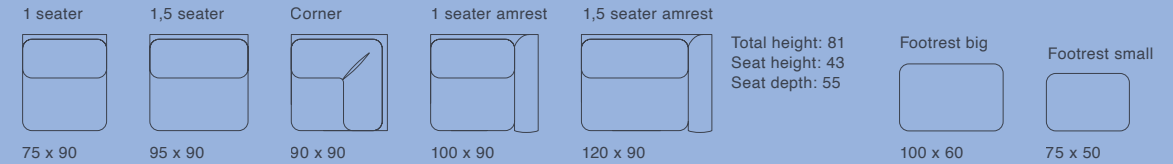

75 x 90

95 x 90

90 x 90

100 x 90

120 x 90

Total height: 81
 Seat height: 43
 Seat depth: 55

Footrest big

100 x 60

Footrest small

75 x 50

EXAMPLE COMBINATIONS All parts can be mirrored



1 seater armrest + 1 seater +
 1 seater armrest
 275 x 90

1,5 seater armrest +
 1,5 seater armrest
 240 x 90

1 seater armrest +
 1 seater armrest
 200 x 90



1 seater armrest + 1,5 seater +
 1,5 seater + 1 seater armrest
 390 x 90

1,5 seater armrest + 1,5 seater +
 1,5 seater + 1,5 seater armrest
 430 x 90

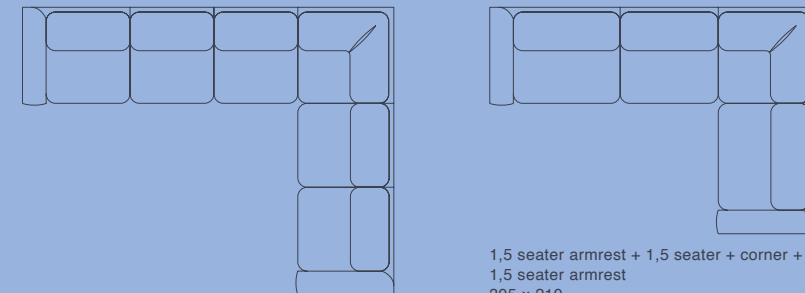

1 seater armrest + 1 seater + 1 seater +
 corner + 1 seater + 1 seater armrest
 340 x 265

1,5 seater armrest + 1,5 seater + corner +
 1,5 seater armrest
 305 x 210

Tondo Sofa

SECTIONS All parts can be mirrored

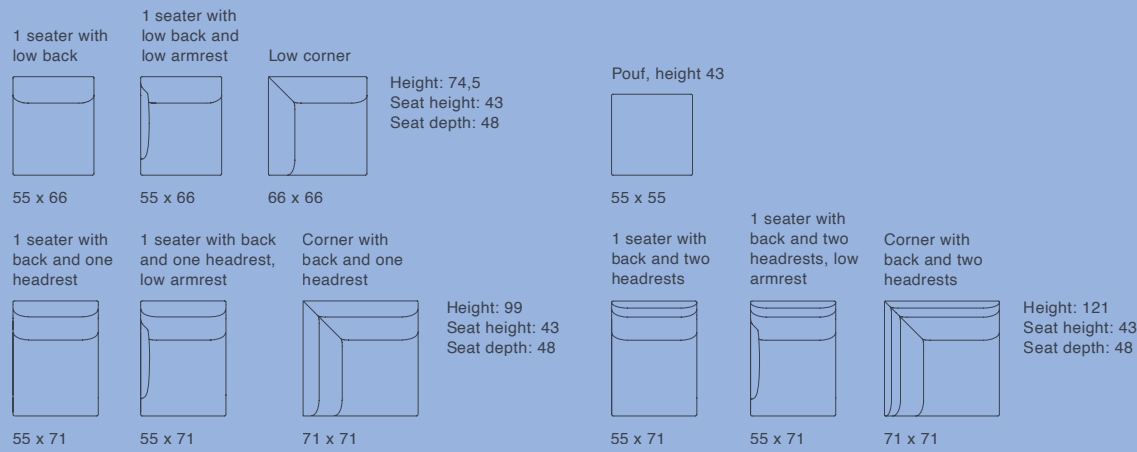

EXAMPLE COMBINATIONS All parts can be mirrored

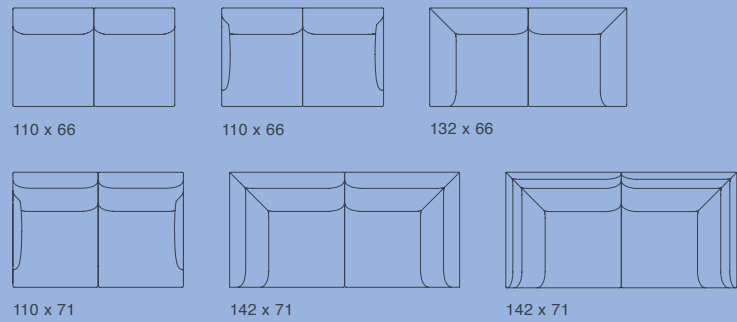

Tondo Lounge Chair & Armchair

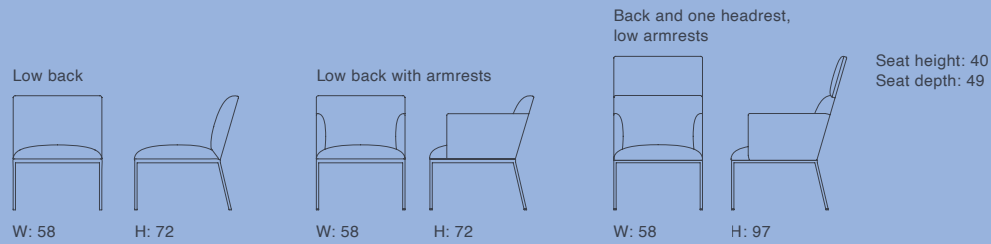

Spisolini

Chair, seat height: 47, seat depth: 44

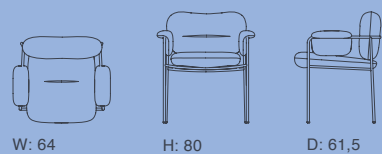

Bollo

Armchair, seat height: 42,5, seat depth: 58

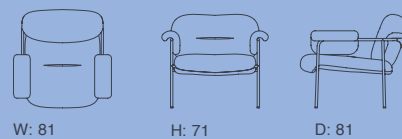

Alex Low / Alex High

SECTIONS All parts can be mirrored

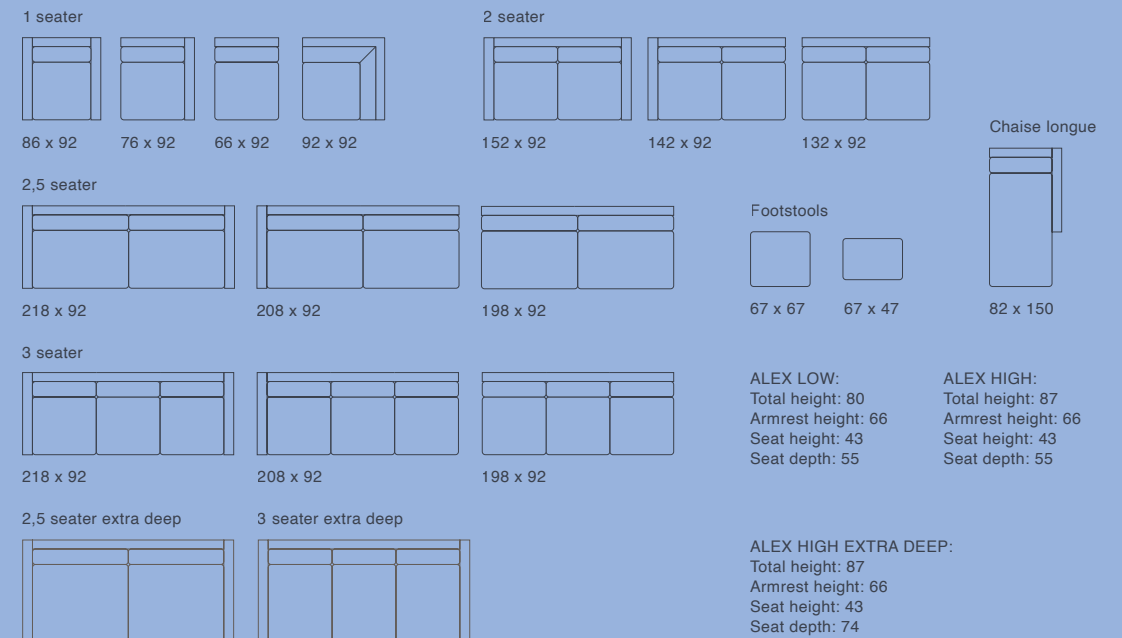

EXAMPLE COMBINATIONS All parts can be mirrored

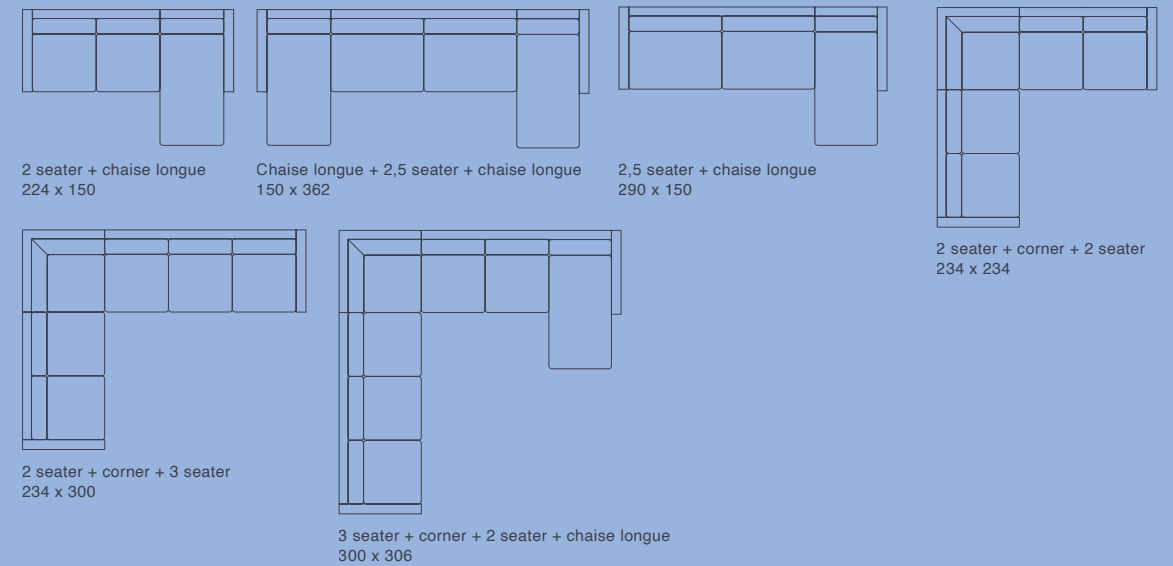

Retreat

SECTIONS All parts can be mirrored

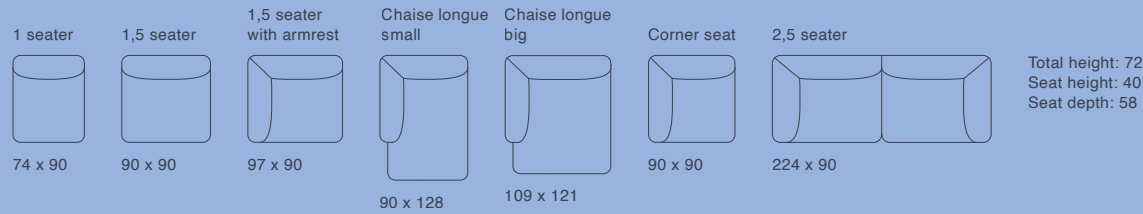

EXAMPLE COMBINATIONS All parts can be mirrored

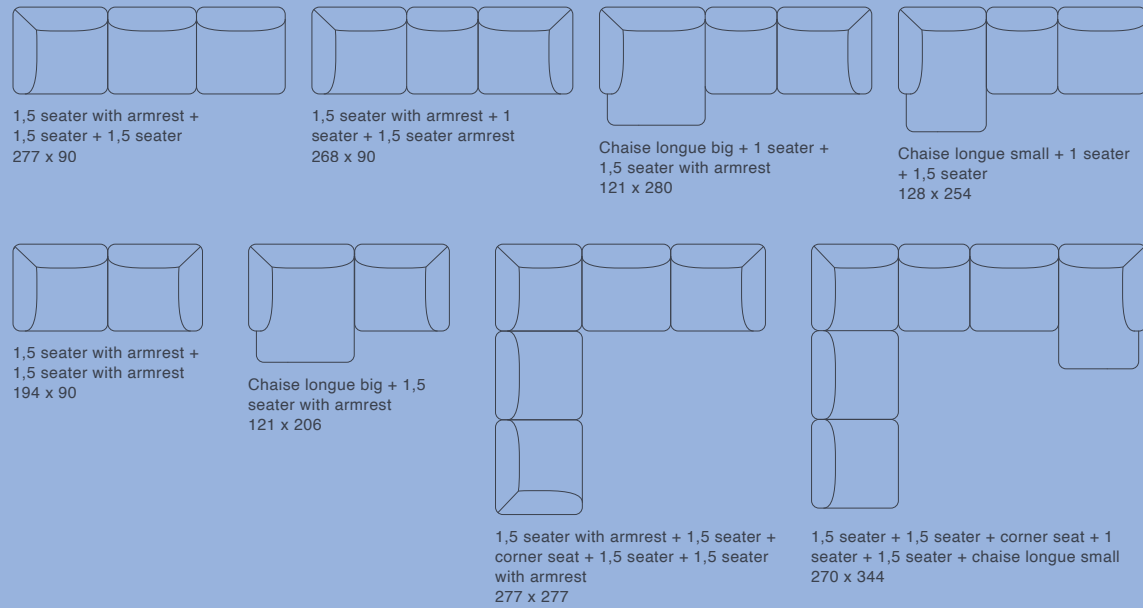

Fragment

SECTIONS All parts can be mirrored

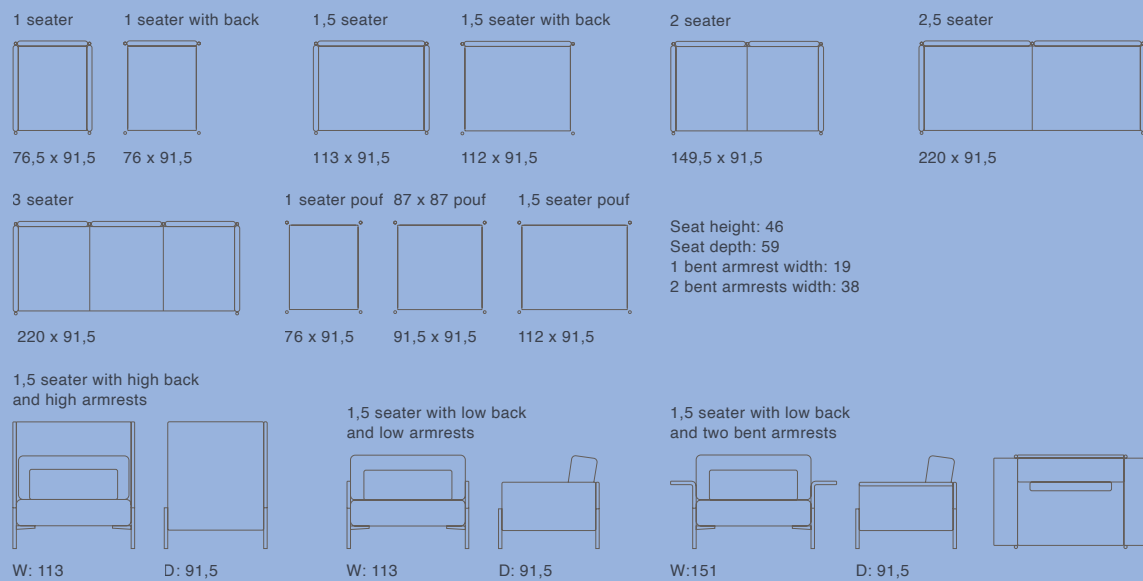

Jord

SECTIONS All parts can be mirrored

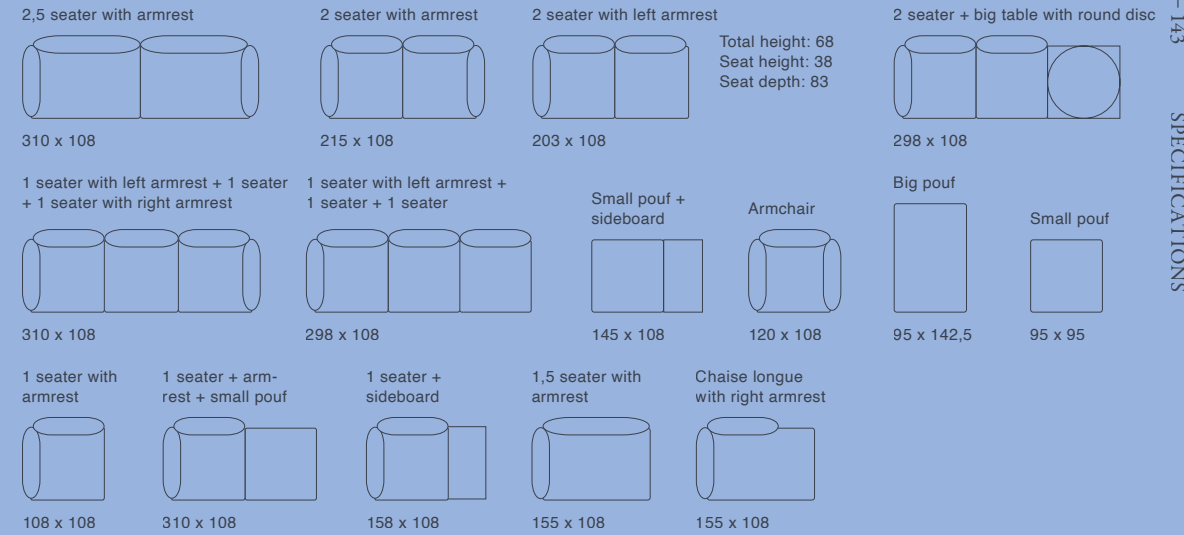

EXAMPLE COMBINATIONS All parts can be mirrored

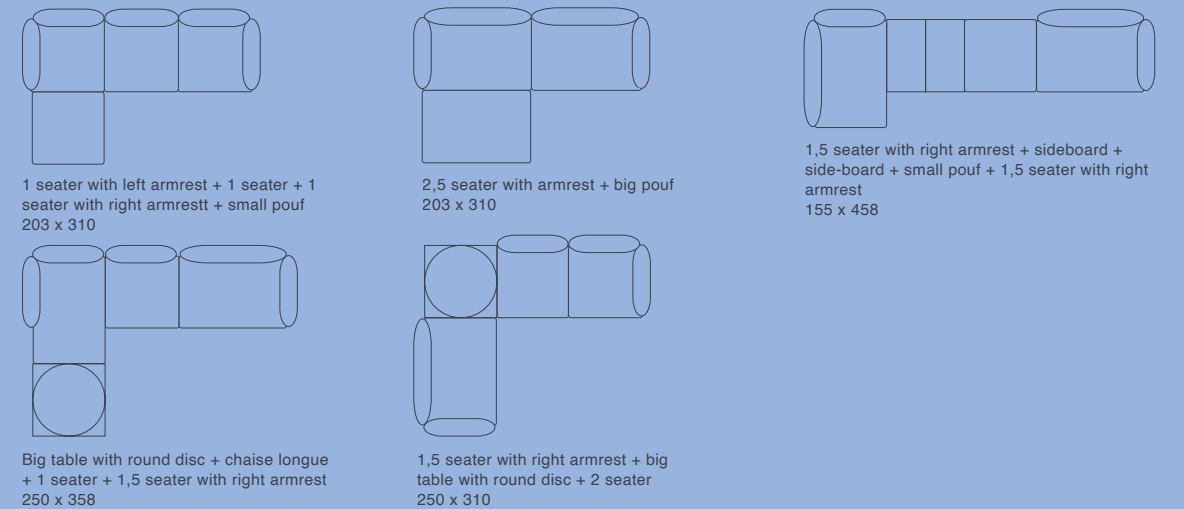

Velar

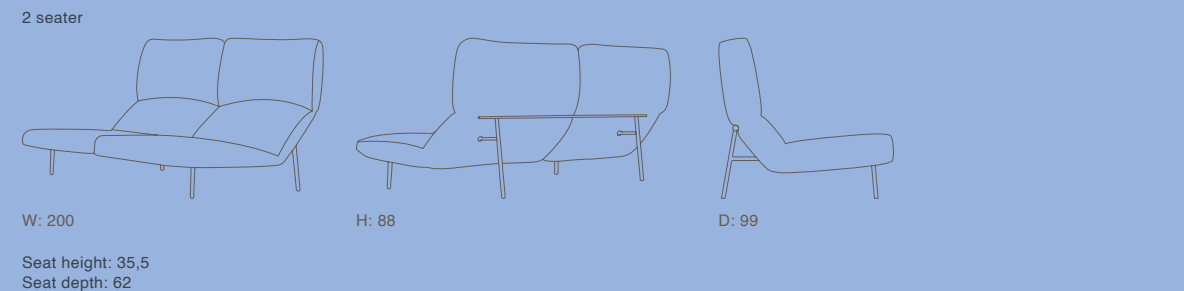

Myko

Chair with metallic frame

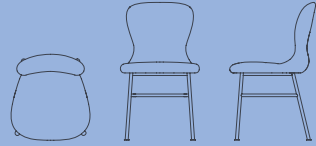

W: 48 H: 86 D: 58

Chair with armrests and wheels, metallic frame

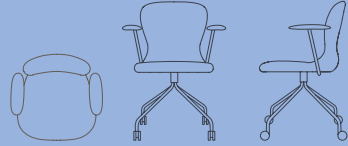

W: 60,5 H: 86 D: 58

Chair with wooden frame

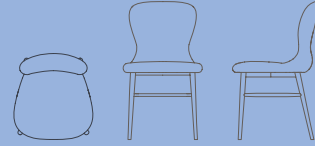

W: 48 H: 86 D: 58

Seat height: 45
Seat depth: 45

Figurine

Chair, seat height 45,5

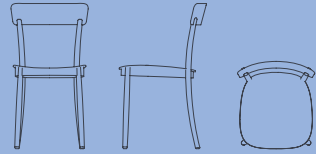

W: 41,5 H: 80,7 D: 48,5

Barstool

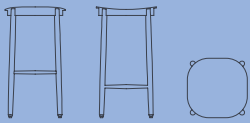

W: 36 H: 65 D: 36

Stool



W: 36 H: 45 D: 36

Poppy

Poppy big

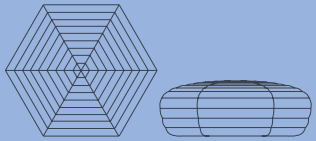

W: 90 H: 43

Poppy small

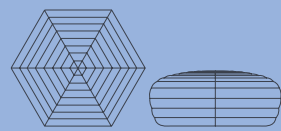

W: 70 H: 43

Poppy low

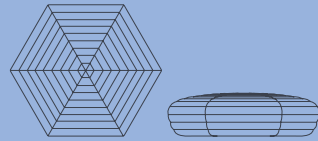

W: 95 H: 27

Embrace

Seat depth: 48 , seat height: 44

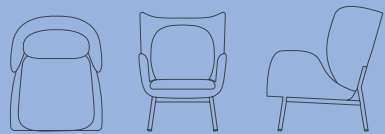

W: 68 H: 89 D: 86

Enclose

Seat height:46, seat depth: 50

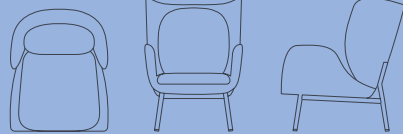

W: 78 H: 105 D: 100

Embody

Footstool

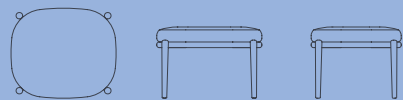

W: 56 H: 38 D: 48

Utility

Large



100 x 32 Small 70 x 28

Mame

Armchair, seat height: 45, seat depth: 64

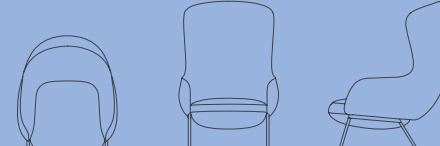

W: 78,5 H: 121 D: 96

Footstool

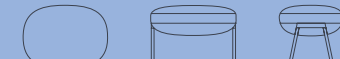

W: 60 H: 45 D: 45

Barba

Sofa, depth: 80

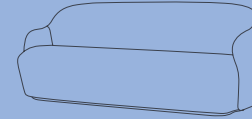

W: 190, H: 78

Armchair, depth: 71



W: 70, H: 70

Seat height: 43,5
Seat depth: 46,5

Niche

Sofa

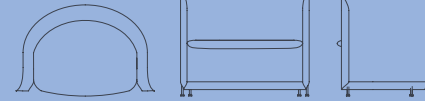

W: 102 H: 88 D: 76

Armchair

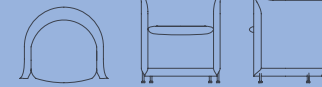

W: 66 H: 73 D: 60

Mono

Metal base without armrest



W: 47 H: 81 D: 38,5

Metal base with armrest

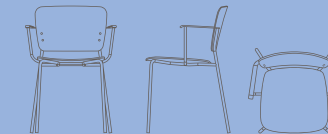

W: 56 H: 81 D: 38,5

Swivel base without armrest



W: 47 H: 81 D: 38,5

Swivel base with armrest



W: 56 H: 81 D: 38,5

Available with adjustable knob
Adjustable height: 80 / 92
Adjustable seat height: 46 / 59

Wooden base without armrest

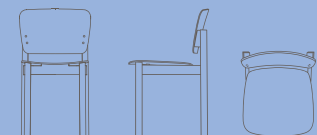

W: 43 H: 82 D: 51

Seat height: 46
Seat depth: 38,5
Armrest height: 69,5

Tables

Supersolid

Supersolid Object 1

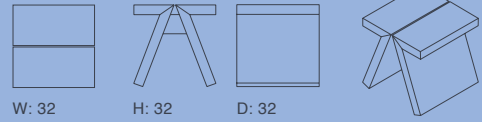

W: 32 H: 32 D: 32

Supersolid Object 2

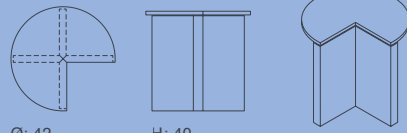

Ø: 42 H: 40

Supersolid Object 3

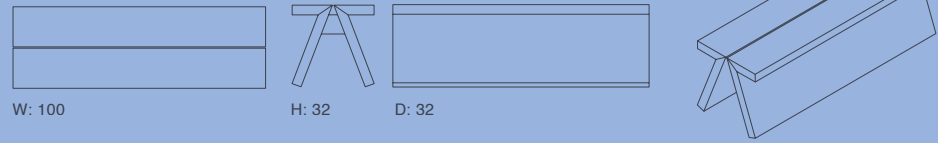

W: 100 H: 32 D: 32

Supersolid Object 4

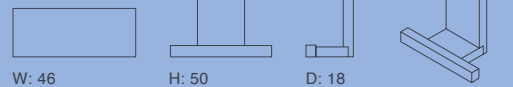

W: 46 H: 50 D: 18

Supersolid Object 5

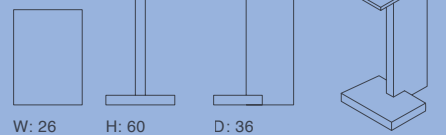

W: 26 H: 60 D: 36

Area

Coffee table area wide low

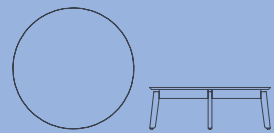

Ø: 80 H: 28

Coffee table area wide high

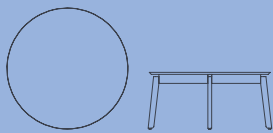

Ø: 80 H: 39

Lamp table



Ø: 45 H: 42

Lara

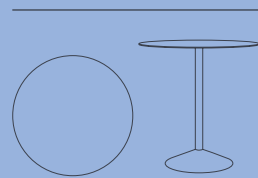

Ø: 70 H: 72

Big Sur

Table

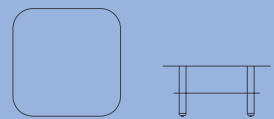

95 x 95 H: 45 Shelf: 76 x 76

Desk

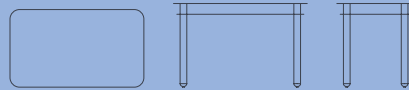

120 x 45 H: 75

Grande

Length: 270

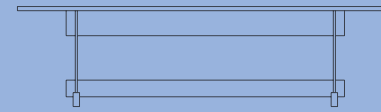

H: 72

Length: 245

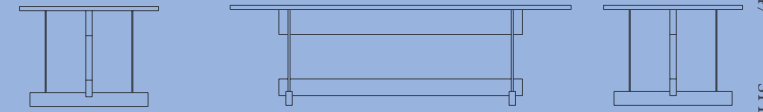

W: 100

H: 72

W: 100

Figurine



180 x 90

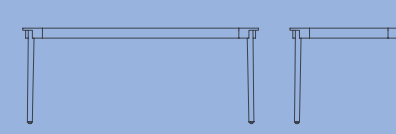

H: 73

Pastille

Side table



Ø: 48

H: 50

Supper

Small

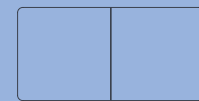

180 x 90

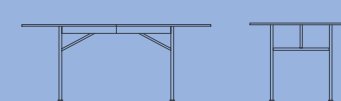

H: 73

Medium

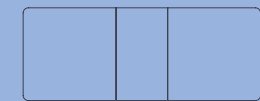

230 x 90

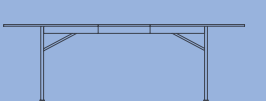

H: 73

Large

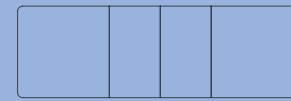

280 x 90

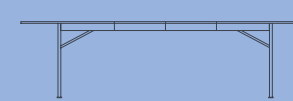

Round



Ø: 127

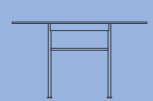

Koku

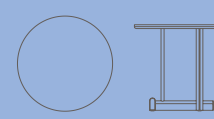

Ø: 50

H: 45

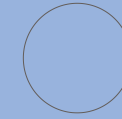

Ø: 80

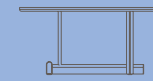

H: 35 / 42



120 x 60

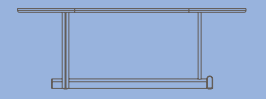

H: 35 / 42

Tabula

Large

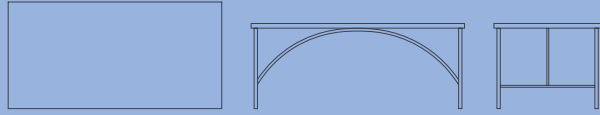

100 x 50

H: 40

Large square

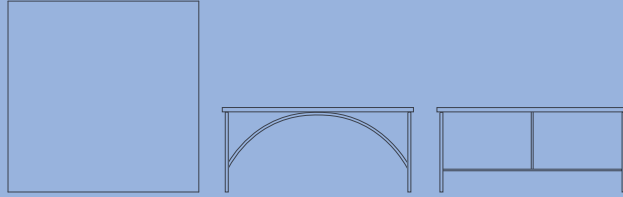

90 x 90

H: 40

Copper

Sofa table

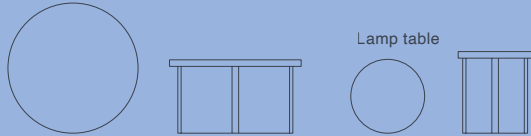

Ø: 80

H: 37 / 45

Lamp table



Ø: 45

H: 32 / 40

Bowl

Big

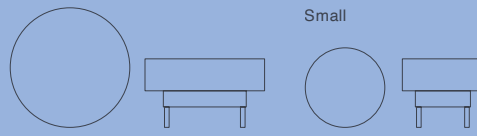

Ø: 60

H: 35,5

Small

Ø: 40

H: 35,5

Jord

Base table

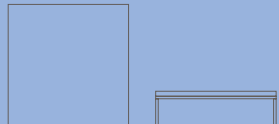

95 x 95

H: 16

Base table with rectangular disc

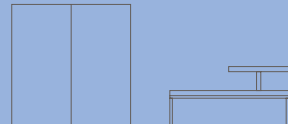

95 x 95 / 47,5

H: 38,5

Base table with round disc



95 x 95, Ø: 95

H: 38,5

Complex

Nesting table

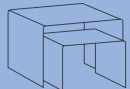

W: 60,5 / 67,

H: 47 / 50, D: 40

Shelves & Storage

Bond

Modular shelving system which can be assembled without tools. Choose from floor standing, wall fixed or ceiling hung. Go to fogia.se/bond_config to create your own and explore its endless variations.

Here are some configuration examples.

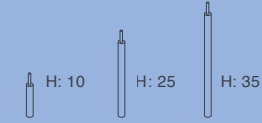
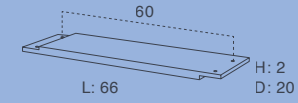

Bond W103 – Wall Mount

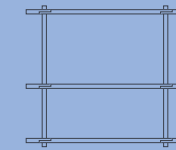

78 x 70

Bond W106 – Wall Mount

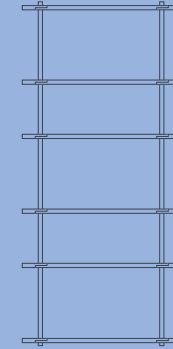

78 x 171

Bond W206 – Wall Mount

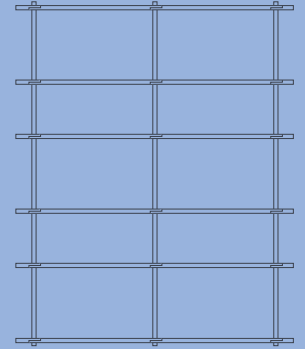

138 x 171

Bond W406 – Wall Mount

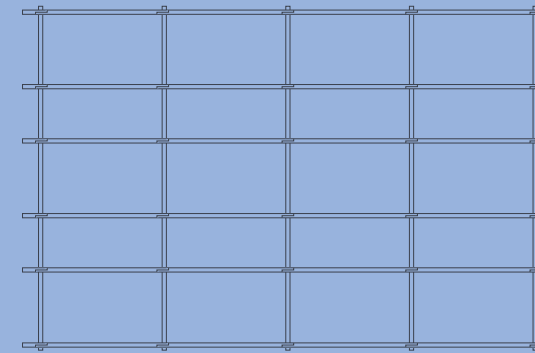

258 x 171

Bond W406D – Wall Mount

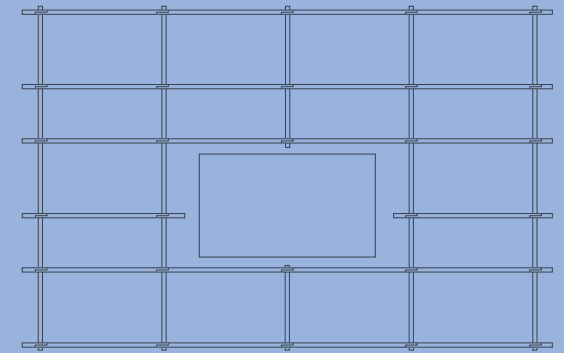

258 x 171

Bond FC4041 – Ceiling Mount

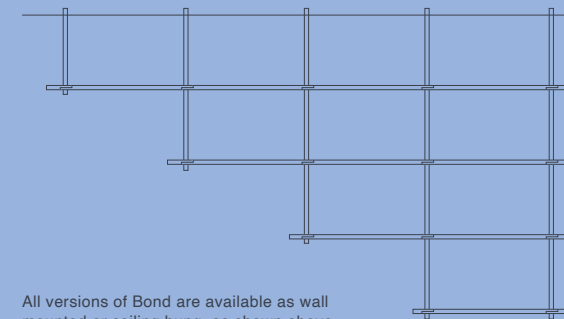

258 x 150

Bond W405 – Wall Mount

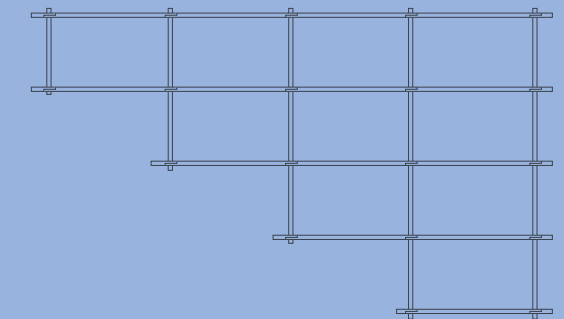

258 x 150

All versions of Bond are available as wall mounted or ceiling hung, as shown above. Plus floor mounted if desired, not shown.

Boss

Bureau, depth: 41,5

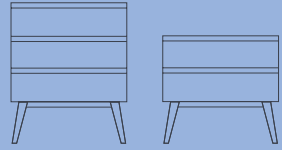

3 drawers
90 x 109

2 drawers
90 x 83

Cabinet, depth 41,5

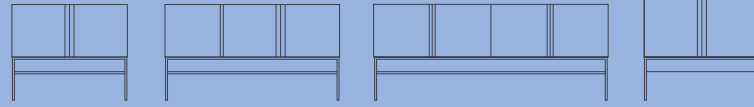

2 doors
90 x 73

3 doors
135 x 73

4 doors
180 x 73

2 doors
90 x 109

Combiplx

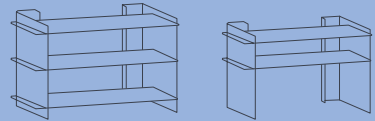

W: 85, H: 82, D: 38

W: 140, H: 70, D: 39

Archetto

Wall hanging shelf
Frame thickness: 2,2



Ø: 25

H: 25

Arch

Wall hanging or floor standing shelf
Low, depth 32,5



118 x 40

Mini, depth: 18,6



59 x 44,6

High, depth 32,5

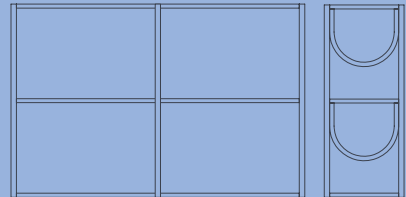

118 x 78

Lighting

Persimon

Cluster

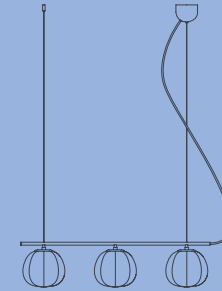

H: 19, Ø: 22,5, Total width: 100

Small



H: 19, Ø: 22,5

Big



H: 38, Ø: 45

Table big

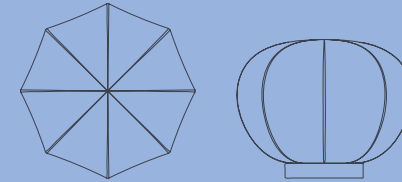

H: 40, Ø: 45

Table small

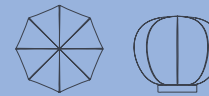

H: 22, Ø: 22,5

Publisher: Fogia
Editor: Richard Prime
Art Direction: Note
Photography: Lasse Fløde
Frida-My, Trine Hisdal,
Mathias Nero, Staffan
Sundström, Note, Jonas
Bjerre-Poulsen
Production: Göteborgs-
tryckeriet, 2022

HQ & Concept Store:
Finnboda Varvsväg 19A
131 72 Nacka, Sweden
Phone: +46 855 609 100
E-mail: info@fogia.se
Please visit fogia.se

FOGIA's pieces are created with individuals whose story is told through their work. Designers who are given space and time in which to create and bring forth their narratives. Working with FOGIA and the artisans at our factory, they create without compromise of materials, construction or creative scope. A true rarity in this age.

Good design is timeless, and these sagas of creative pursuit are what makes it so.