

101

C O P E N H A G E N

TRIBU LOUNGE CHAIR // ASSEMBLY INSTRUCTIONS

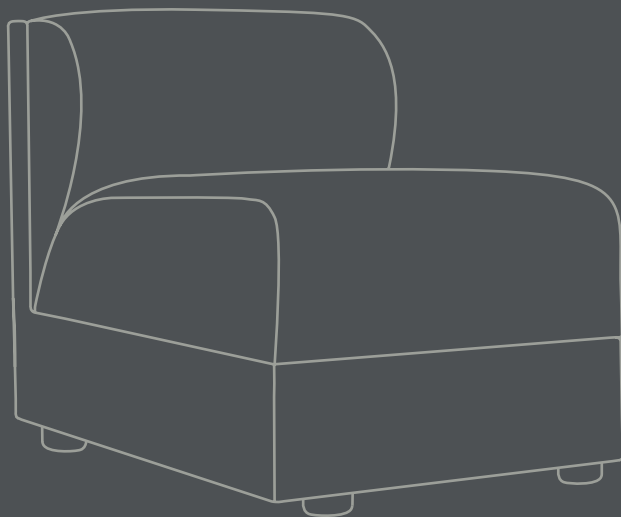



ABOUT 101 COPENHAGEN

101 Copenhagen is a Danish design brand founded in 2017. With a vision to honor exquisite quality and craftsmanship, the collection encompasses furniture, lighting and accessories in a timeless, yet modern design. With a true passion for materials and refined textures, organic shapes and colours, 101 Copenhagen presents the epitome of classics and must-have novelties for Scandinavian and international interior connoisseurs alike.

OUR CREATIVE DRIVE

The design of 101 Copenhagen is firmly rooted in the Scandinavian soil and nourished by Japanese minimalist aesthetics. Sharing an emphasis on quality materials, techniques and traditions, the meeting between the North and the East is notable in the holistic collections of 101 Copenhagen. The design approach is dynamic and characterised by freedom of expression - creating unique and timeless pieces without compromising on playfulness and individuality.

OUR DESIGN TEAM

An attention to detail and a shared sense of aesthetics is what drives the two main designers of 101 Copenhagen, Tommy Hyldahl and Kristian Sofus Hansen. Merging their backgrounds and experiences from the fashion industry, the Royal Danish Academy of Fine Arts and travels in Japan respectively, a narrative of minimalist, sculptural and conceptual design is evident throughout the collections. Translating and transforming the simplistic inspiration from Japan in a Scandinavian context is all about honouring quality, heritage and materiality while never seizing to compromise on form and function. Trained as an architect, the third designer, Nicolaj Noddesbo, adds knowledge on innovative light solutions and timeless novelties to the 101 Copenhagen collections. 101 Copenhagen is a curated selection of tactile, bold objects standing out in a crowd and gathers as a whole.

**CONGRATULATIONS
ON YOUR NEW PRODUCT FROM
101 COPENHAGEN**



101

C O P E N H A G E N

TRIBU LOUNGE CHAIR

Inspired by old tribal sculptures, the TRIBU collection is made of a fiber concrete base with a soft upholstered cushion on top. Characterized by a surface of architectural concrete lamellas, TRIBU emphasizes the fine balance between sharp architectural lines and a somewhat softer curve of the upholstery seat. Combine several TRIBU Lounge Chairs to create a sofa lounge seating. Each TRIBU Lounge Chair includes two mounting brackets, which can be mounted underneath each leg and easily tightened with a screw. The TRIBU Collection comprises a chair, bench, and stool cast in lightweight fiber concrete for increased mobility. The product is hand painted to create a unique surface texture with delicate colour variations. Each product is complemented by a soft cushion, meticulously upholstered for added comfort. The Tribu lounge chair features a cushion crafted in Taupe-colored Sunproof fabric. This particular fabric boasts high resistance to stains, water, and sunlight, ensuring that maintenance is effortless, and the appearance remains fresh. Additionally, the cushions for the bench and stool are beautifully finished in an elegant off-white linen, enhancing their aesthetic appeal.

Designed by Kristian Sofus Hansen & Tommy Hyldahl.

Product no: 233001

Type: Lounge Chair

Designer / Year of design:
Kristian Sofus Hansen & Tommy Hyldahl, 2022

Colour: Taupe
Material: Sunproof fabric

Care instructions: Sunproof fabric is carefully processed and has gone through a special treatment to reduce the fabric absorption in terms of soil and stains. The fabric is water repellent and is protected by an invisible shield around each of its fiber for keeping the fabric dry and clean. Sunproof fabric is resistant to UV damage and fading.

Remove stains by using a brush or wet cloth.
Vacuum clean to remove loose dirt.
Use a gentle cleaning solution.
Rinse off any remaining soap or cleaning agents.

Dimensions: L61 / W88 / H72 CM
Weight capacity: 150 Kgs

Country of origin: CN
Product weight: 35 Kgs

Packaging:
Dimensions: L102,5 / W72,5 / H85,5 CM
Total weight incl. product: 37,5 Kgs
Number of parcels: 1
Material: Brown cardboard

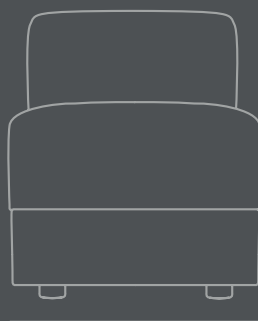

61 CM

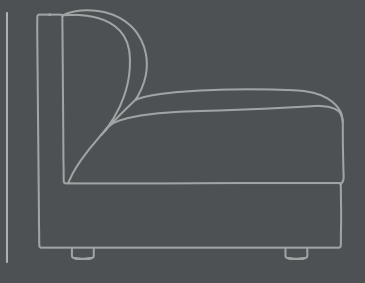

72 CM

44 CM

88 CM

TO ASSEMBLE:

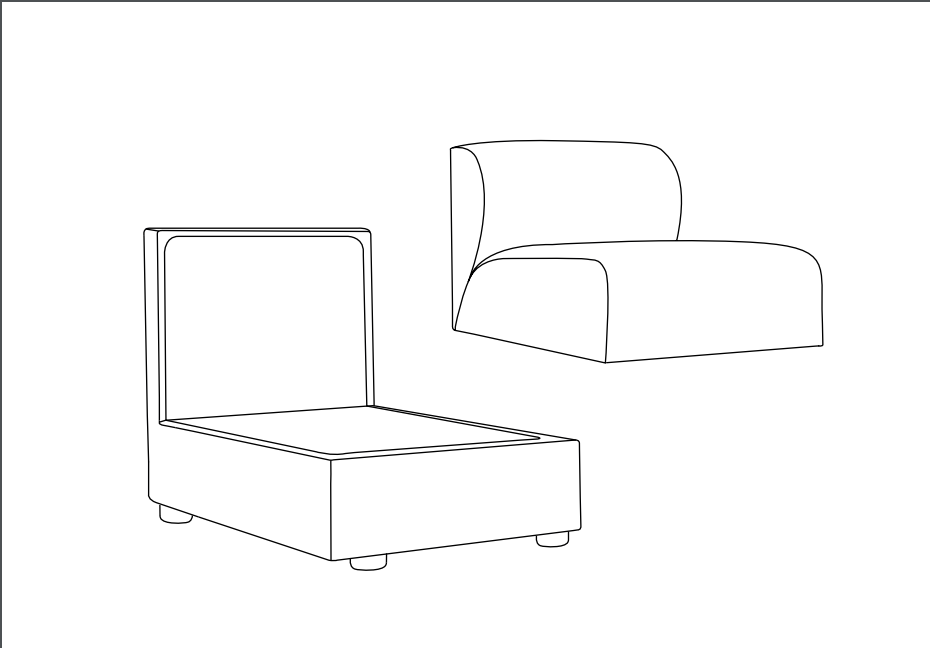

1. The product consists of two components: A fiber concrete base and a cushion. Carefully open the package and remove the cushion.

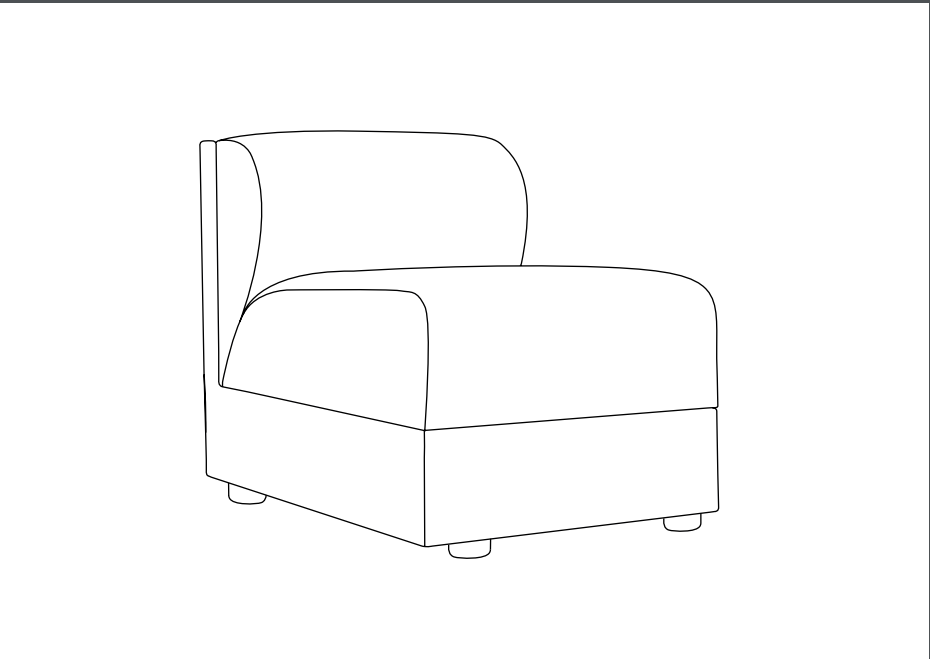

2. Place the cushion within the line of the fiber concrete base. Ensure that it aligns properly with the base for a snug fit.

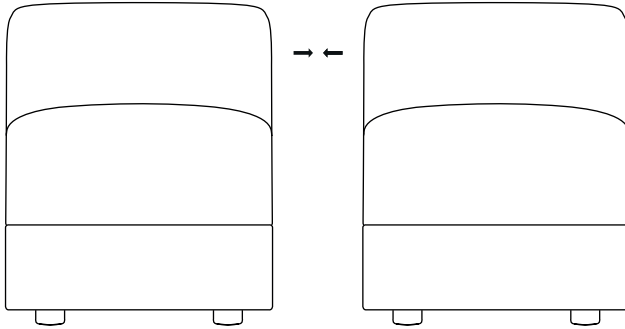
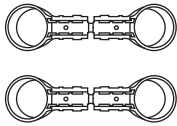

3. **Joining Multiple Chairs (Optional).** If you have purchased multiple chairs and wish to join them together, follow these additional steps. Inside the box of each chair, you will find two connectors provided.

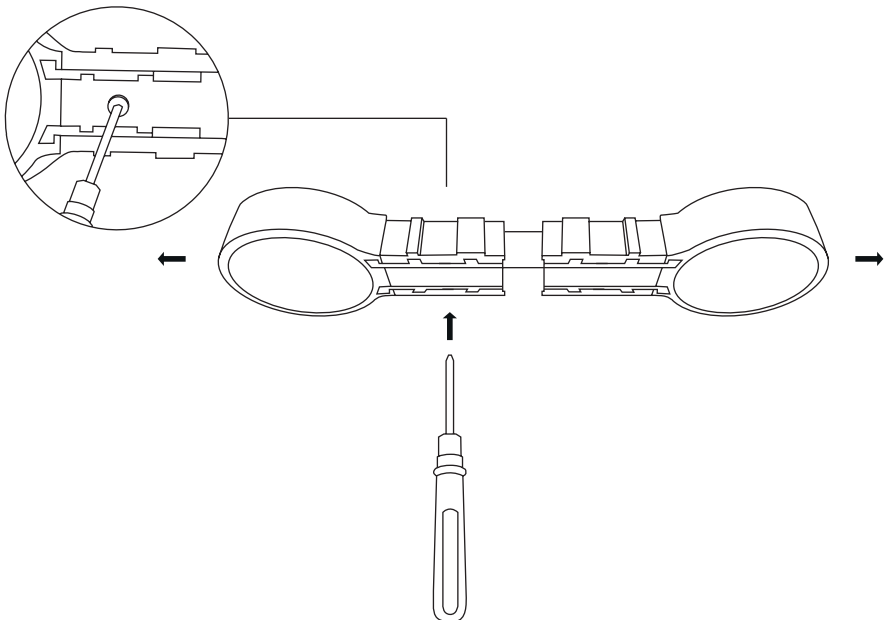

4. Use a screwdriver to adjust the connectors so that they can reach both legs of the chairs placed side by side.

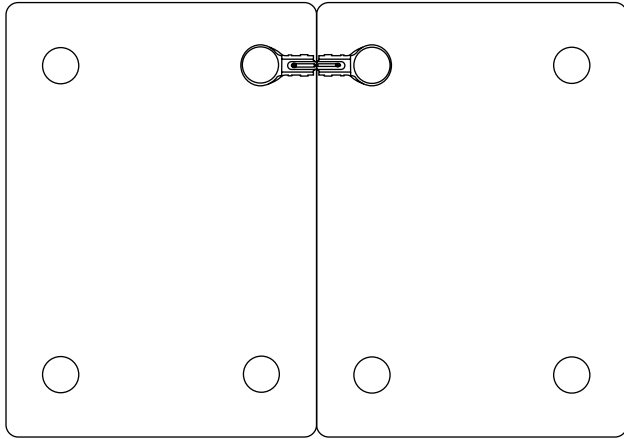

5. The connectors should be positioned at the junction where the chairs meet.

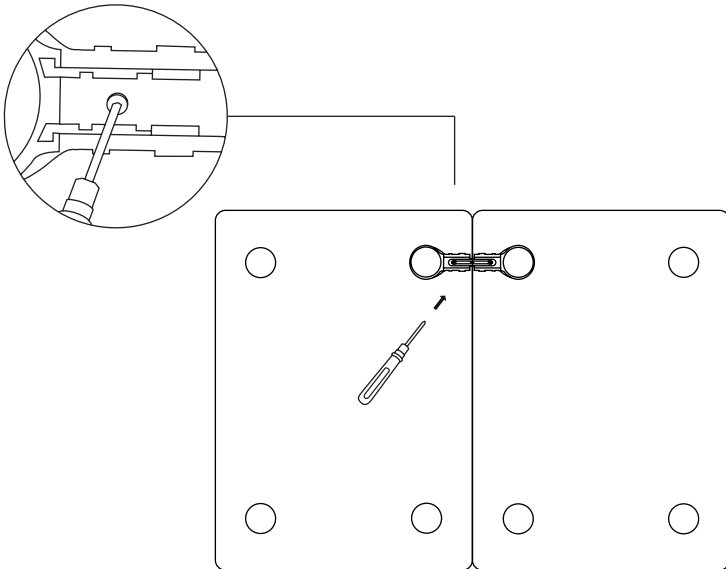

6. With the connectors in place, securely tighten the screws using the screwdriver. Ensure that the connectors are firmly attached to both chair legs.

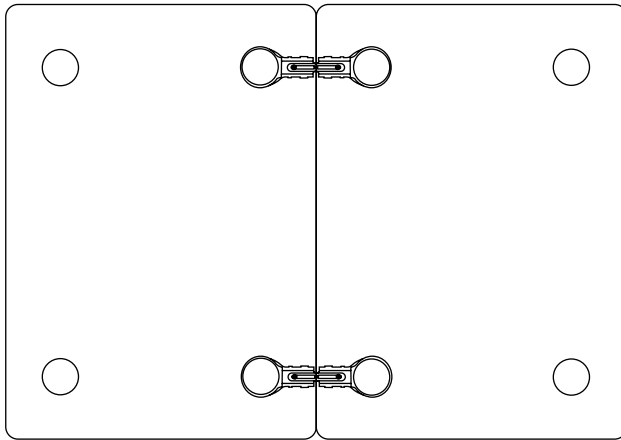

7. Repeat this process to join the second pair of legs.

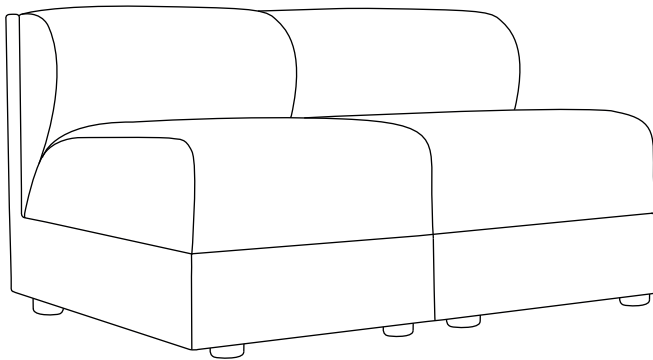

8. After completing the assembly, make sure all screws are tightened securely. Double-check that the cushion is properly positioned on the base.



GLOBAL SALES INQUIRIES: SALES@101CPH.COM
SUPPORT INQUIRIES: SUPPORT@101CPH.COM
PRESS INQUIRIES: PRESS@101CPH.COM



PRESS KIT & IMAGEBANK PLEASE GO TO:

WWW.101CPH.COM OR SCAN THE QR CODE AND GAIN ACCESS TO OUR IMAGE BANK, CATALOGUE AND MORE.
SHOWROOM BY APPOINTMENT ONLY // ØSTERGADE 17, 3RD & 4TH FLOOR, 1100 COPENHAGEN, DENMARK.